

# Thermopile Detector

## TPD 2T 0625 G2 G20 / 3176

Revision - Date: 2018/03/12



### Features and Benefits

- High sensitivity
- TO-39 metal housing
- Thermistor included
- Two narrow band pass filters

### Applications

- High precision gas sensing and monitoring

## 1 General Characteristics

**Table 1: Absolute Maximum Ratings**

Symbol	Parameter	Min	Typ	Max	Unit	Conditions
T <sub>A</sub>	Ambient Temperature Range	-20		100	°C	Operation
T <sub>A</sub>	Ambient Temperature Range	-40		100	°C	Storage

## 2 Type Characteristics

### 2.1 Design Characteristics

The detector fully complies with the European RoHS environmental directives against the use of hazardous materials in electrical and electronic equipment.

**Table 2: Design Characteristics**

Parameter	Description
Cap	Metal cap with 2 integrated IR windows
Leads	(3 isolated + 1 ground) pins
Filter type	IR band pass filters
Temperature reference	Thermistor 100 kΩ
Device marking	4 digits device number XXXX + 4 digits date code YYWW

## 2.2 Electrical Characteristics

**Table 3: Thermopile Detector Characteristics**

Symbol	Parameter	Value	Unit	Conditions
A	Sensitive Area	1,2 x 1,2	mm <sup>2</sup>	Absorber area
R <sub>TP</sub>	Thermopile Resistance	50...110	kΩ	25 °C
S	Sensitivity	10...30 (T1) 15...35 (T2)	μV/K	T <sub>BB</sub> =500 K
t	Time Constant	27	ms	
V <sub>N</sub>	Noise Voltage	36	nV/√Hz	25 °C
D*	Specific Detectivity	1.1	10 <sup>8</sup> cm√Hz/W	25 °C
TC <sub>RTP</sub>	Temperature Coefficient of Resistance	0.03	%/K	
TC <sub>R</sub>	Temperature Coefficient of Responsivity	-0.05	%/K	
R25	Thermistor Base Resistance	100 ± 5	kΩ	25°C
β	Thermistor BETA -Value	3964	K	Defined at 25°C / 100°C
β	Thermistor BETA -Value Tolerance	± 0.3	%	

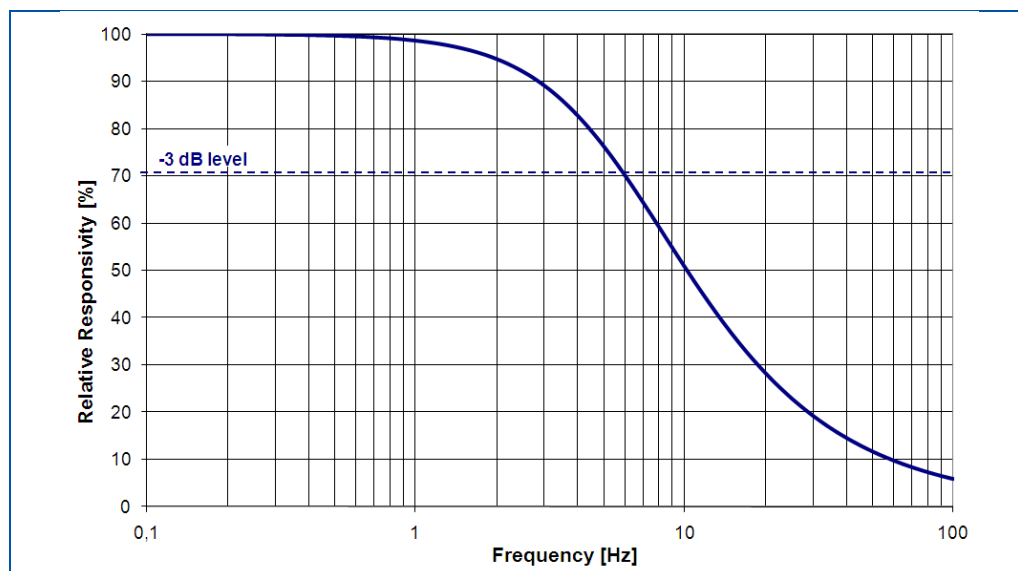

**Figure 1 Detector Responsivity as a Function of Frequency**

Figure 1 shows the relative signal output as a function of the thermal radiation signal chopping frequency. The -3 dB level at 71% relative output level defines the cut-off frequency  $f_{co}$  and thus the time constant  $\tau$  via  $\tau = 1/2\pi f_{co}$ .

**Table 4: Tabulated Thermistor Data**

Temp.	R <sub>min1</sub>	R <sub>min2</sub>	R <sub>nom</sub>	R <sub>max2</sub>	R <sub>max1</sub>	Temp.	R <sub>min1</sub>	R <sub>min2</sub>	R <sub>nom</sub>	R <sub>max2</sub>	R <sub>max1</sub>
°C	Ω	Ω	Ω	Ω	Ω	°C	Ω	Ω	Ω	Ω	Ω
-20	862756	909418	915479	921581	968201	45	41833	44067	44175	44283	46516
-15	655207	690548	694575	698625	733944	50	34541	36387	36497	36608	38453
-10	501697	528693	531349	534018	561001	55	28662	30195	30303	30412	31944
-5	387196	407985	409715	411452	432234	60	23898	25176	25280	25385	26663
0	301098	317232	318336	319444	335574	65	20017	21089	21187	21286	22357
5	235852	248468	249149	249832	262445	70	16842	17744	17836	17928	18830
10	186038	195972	196369	196767	206701	75	14231	14994	15079	15165	15927
15	147731	155608	155815	156022	163900	80	12075	12721	12800	12879	13526
20	118070	124357	124439	124521	130808	85	10286	10838	10910	10983	11534
25	95000	100000	100000	100000	105000	90	8796	9268	9334	9401	9872
30	76707	80791	80843	80895	84978	95	7550	7956	8016	8077	8481
35	62328	65649	65732	65815	69137	100	6504	6853	6908	6964	7313
40	50926	53643	53743	53843	56559	105	5623	5925	5975	6026	6327

R<sub>min1</sub> : Minimum Thermistor Resistance resulting from the Total Tolerance  
 R<sub>min2</sub> : Minimum Thermistor Resistance resulting from the BETA-Tolerance  
 R<sub>nom</sub> : Typical Thermistor Resistance  
 R<sub>max1</sub> : Maximum Thermistor Resistance resulting from the Total Tolerance  
 R<sub>max2</sub> : Maximum Thermistor Resistance resulting from the BETA-Tolerance

## 2.3 Optical Characteristics

**Table 5: Optical Characteristics**

Symbol	Parameter	Min	Typ	Max	Unit	Conditions
FoV	Field of View		87		degree	At 50% intensity points
	Optical Axis		0	+/- 10	degree	

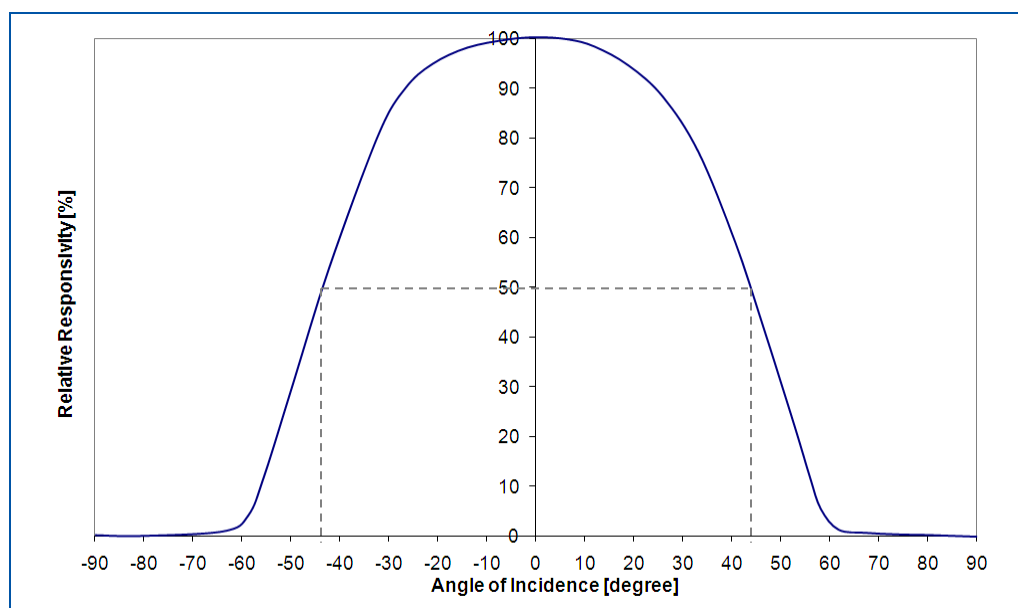

**Figure 2 Typical Field of View Curve**

**Table 6: Filter Specifications**

Channel Number	T1	T2
Filter Identifier	G20	G2
Matched to gas	Reference filter	CO2
Center wavelength (CWL)	3.95 $\mu\text{m}$	4.26 $\mu\text{m}$
CWL tolerance	$\pm 40$ nm	$\pm 30$ nm
Half power bandwidth (HPB)	100 nm	180 nm
HPB tolerance	$\pm 10$ nm	$\pm 20$ nm
HPB / CWL	2.5%	4.2 %
Peak transmittance	> 76 %	> 73 %
Average transmittance from visual to band pass region	< 0.1 %	$\leq 0,1$ %
Peak transmittance value from visual to band pass region	-	$\leq 1$ %
Peak transmittance value from band pass region to 10 $\mu\text{m}$	< 1 %	$\leq 1$ %
Average transmittance from 10 $\mu\text{m}$ to 12 $\mu\text{m}$	< 5 %	$\leq 5$ %
Substrate material	silicon	silicon

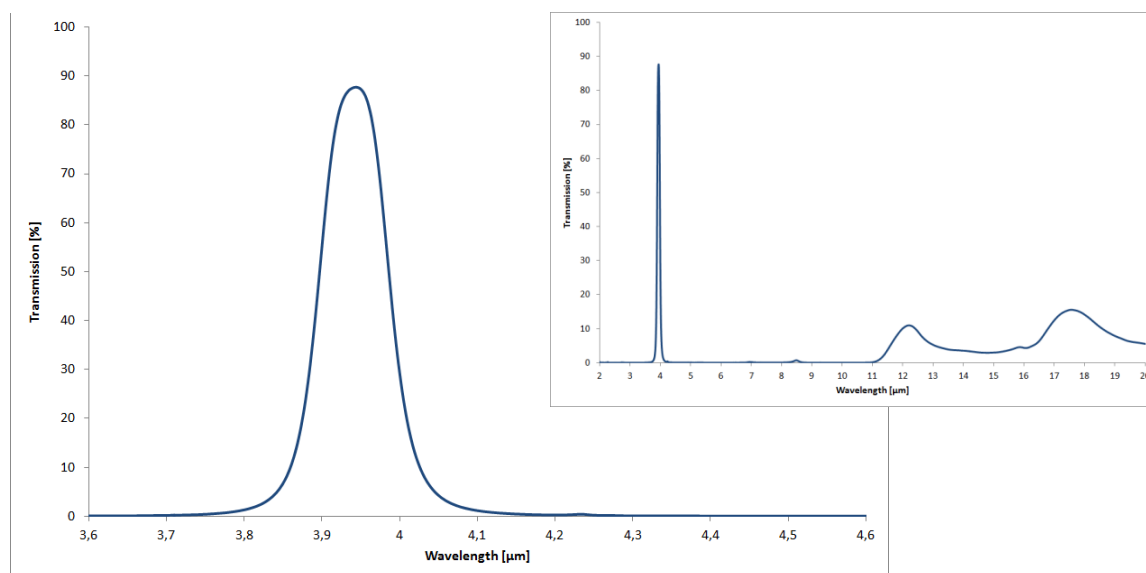
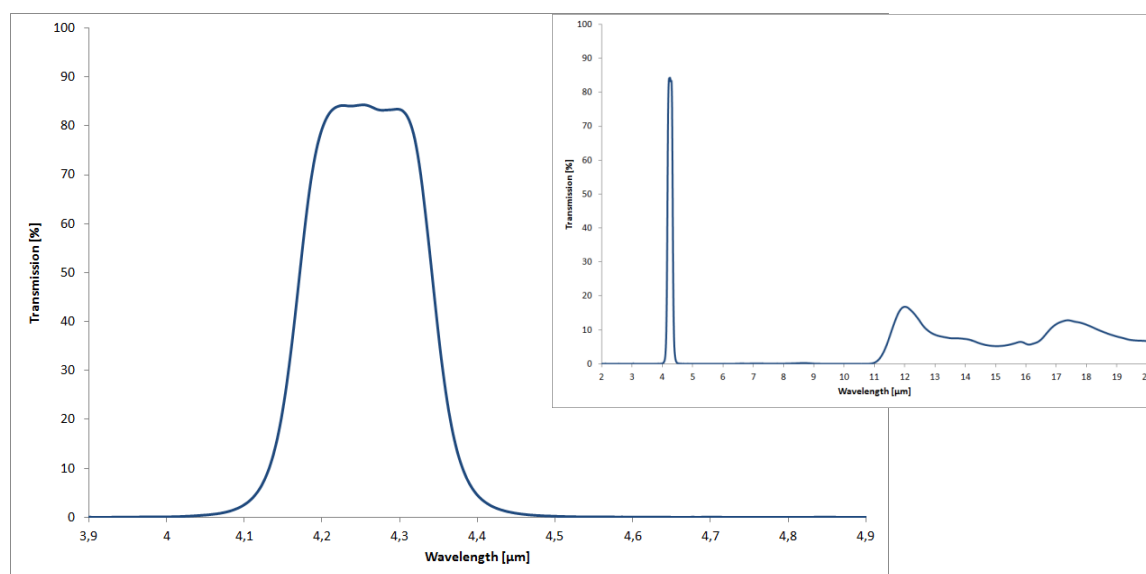
**Figure 3 Typical Transmission Characteristics of Filter G20**

**Figure 4 Typical Transmission Characteristics of Filter G2**

## 2.4 Mechanical Drawing

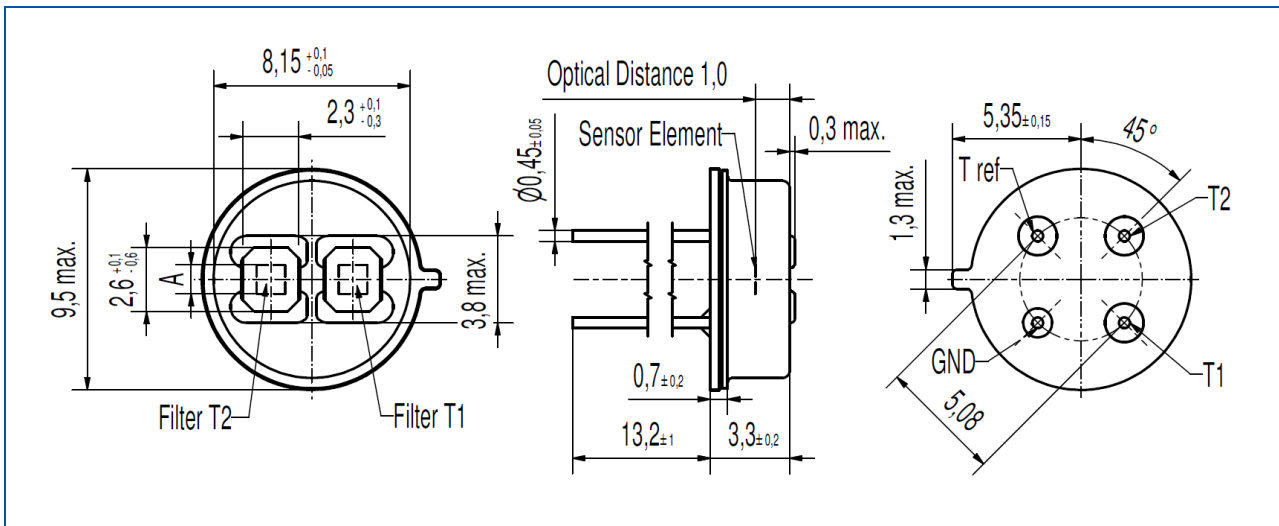
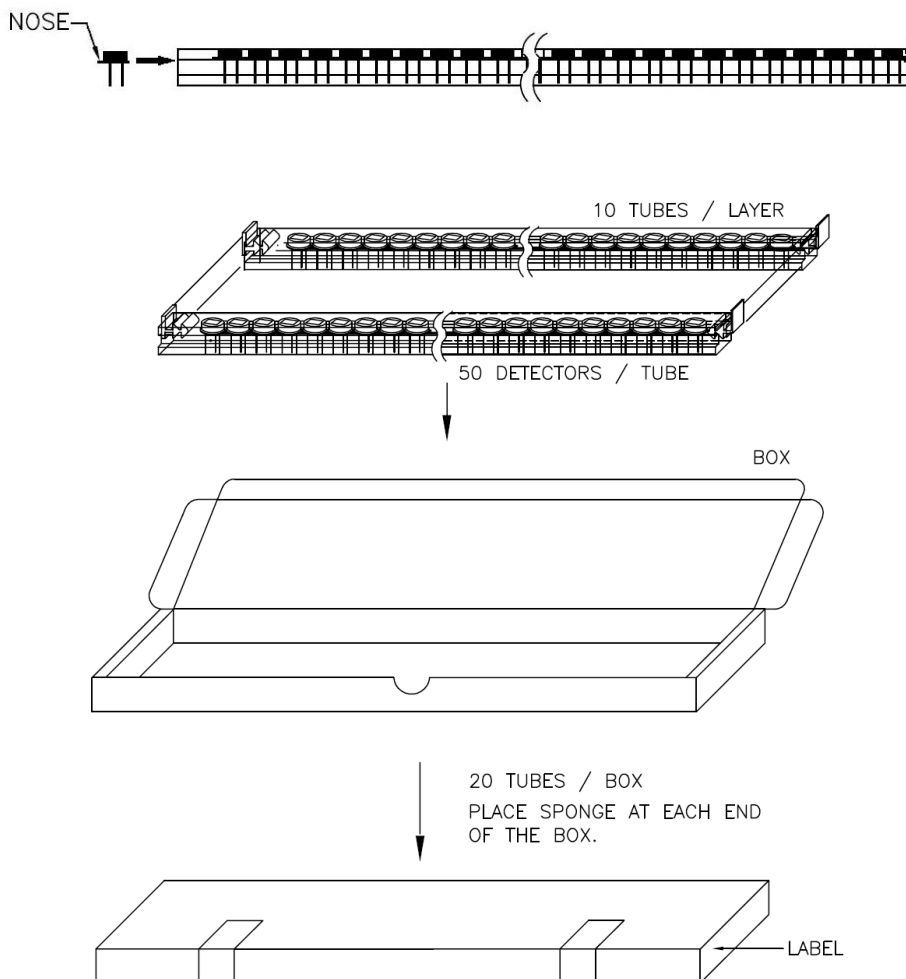

Figure 5 Mechanical drawing of detector TPD 2T 0625 (Drawing No.: 2/71833-0)

## 2.5 Packing Arrangement

Packing box with 1000 pcs. devices.  
 Devices are packed into plastic tubes (50 pcs. / tube).  
 20 tubes / packing box. Box size: 480 x 121 x 52 mm



## 2.6 Handling Requirements

Stresses above the absolute maximum ratings may cause damages to the device. Do not expose the detector to aggressive detergents such as Freon, Trichloroethylene, etc. Windows may be cleaned with alcohol and cotton swab. Hand soldering and wave soldering may be applied by a maximum temperature of 260°C for a dwell time less than 10 s. Avoid heat exposure to the top and the window of the detector. Reflow soldering is not recommended.

## 3 Quality Statement

Excelitas Technologies is an ISO 9001 certified manufacturer. All devices employing PCB assemblies are manufactured according IPC-A-610 guidelines.

### 3.1 Liability Policy

The contents of this document are subject to change without notice and customers should consult with Excelitas Technologies sales representatives before ordering. Customers considering the use of Excelitas Technologies thermopile devices in applications where failure may cause personal injury or property damage, or where extremely high levels of reliability are demanded, are requested to discuss their concerns with Excelitas Technologies sales representatives before such use. The Company's responsibility for damages will be limited to the repair or replacement of defective product. As with any semiconductor device, thermopile sensors or modules have a certain inherent rate of failure. To protect against injury, damage or loss from such failures, customers are advised to incorporate appropriate safety design measures into their product.

Excelitas Technologies GmbH & Co. KG.  
Wenzel-Jaksch-Str. 31  
65199 Wiesbaden, Germany  
Telephone: (+49) 611-492-0  
Fax: (+49) 611-492-177

**EXCELITAS**  
TECHNOLOGIES