

Electrically Tunable Lens EL-10-42-OF-532

The working principle of EL-10-42-OF lens with integrated optical feedback is based on the well-established shape-changing flexible lens. The curvature of the lens is adjusted by applying an electrical current, changing the focal length within milliseconds. The EL-10-42-OF has an integrated optical feedback, measuring the focal power of the lens in real-time. Optimal control is guaranteed using the EL-E-OF-A analog driver board or Optotune-DSD digital driver board developed by SCAPS GmbH. This makes the EL-10-42-OF suitable for a wide range of industrial (marking, engraving, cutting...) and medical applications.



Main specifications

Product	EL-10-42-OF-532	EL-10-42-OF-532-S (SCAPS)	
Clear aperture	10		mm
Maximum operating laser power (average)	20		W
Focal power: tuning range	-2.0 to 0 to +2.0 (-500 mm to infinity to 500 mm)	-1.8 to 0 to +1.8 (-555 mm to infinity to 555 mm)	dpt
Focal power: repeatability	typical: < 0.02 max: < 0.04		dpt
Focal power: long term stab. 8h			
Wavefront error	< 0.3 @ 532 nm		λ RMS
Transmission @ 532 nm	> 95%		
Long term radiation damage @ 532 nm: 1.4 mJ/cm ² at 30 kHz	No effect after 60 h		
Damage threshold ¹ @ 532 nm: 1 ns-pulsed at 300 kHz 10 ps-pulsed at 50 kHz	0.15 0.10		J/cm ²
Response time Controlled with EL-E-OF-A analog board	80% step: 12 20% step: 6		ms
Response time Controlled with Optotune-DSD digital board		80% step: 8 20% step: 4.5	ms
Tracking delay Controlled with Optotune-DSD digital board		< 2	ms
Focal length resolution	Continuous (depends on control electronics)		
Lifecycles (10%-90% sinusoidal)	> 100'000'000		
Weight	90		g
Heater set temperature	47		°C
Operating temperature	10 to 40		°C
Storage Temperature	-20 to 80		°C

Parameters in combination with f = 160 mm f-theta lens²

Max z-tuning range in a marking system	100	90	mm
Repeatability (10%-90% step) ¹	< 500		μm
Long term drift over 8h ¹	< 1000		μm

Electrical specifications

Max lens power consumption	1.5	W
Max lens current	385	mA
Coil resistance @ 25°C	12.5	Ohm
Max heater power consumption	12	W
Heater resistance @ 25°C	25 +/- 10%	Ohm
LED forward voltage	1.5	V

¹ Characterization done by Inspire AG and IWF/ETH Zurich

² See laser processing application note for details

Overview of available standard products

Standard Product	Max Laser Power	Optotune DSD (SCAPS) Compatible
EL-10-42-OF-532-4D-20W	20	No
EL-10-42-OF-532-4D-20W-S	20	Yes

Housing

The EL-10-42-OF comes with a black aluminum housing. Four M3 thread holes located at the front surface of the housing are designated for mounting. A typical assembly is shown in section Alignment and mounting. The $\varnothing 40.0$ mm and $\varnothing 25.5$ mm diameter flanks are tightly tolerated (ISO tolerance g6) and suitable as alignment features. The included Teflon washer provides thermal isolation and must be placed between the EL-10-42-OF and an external holder.

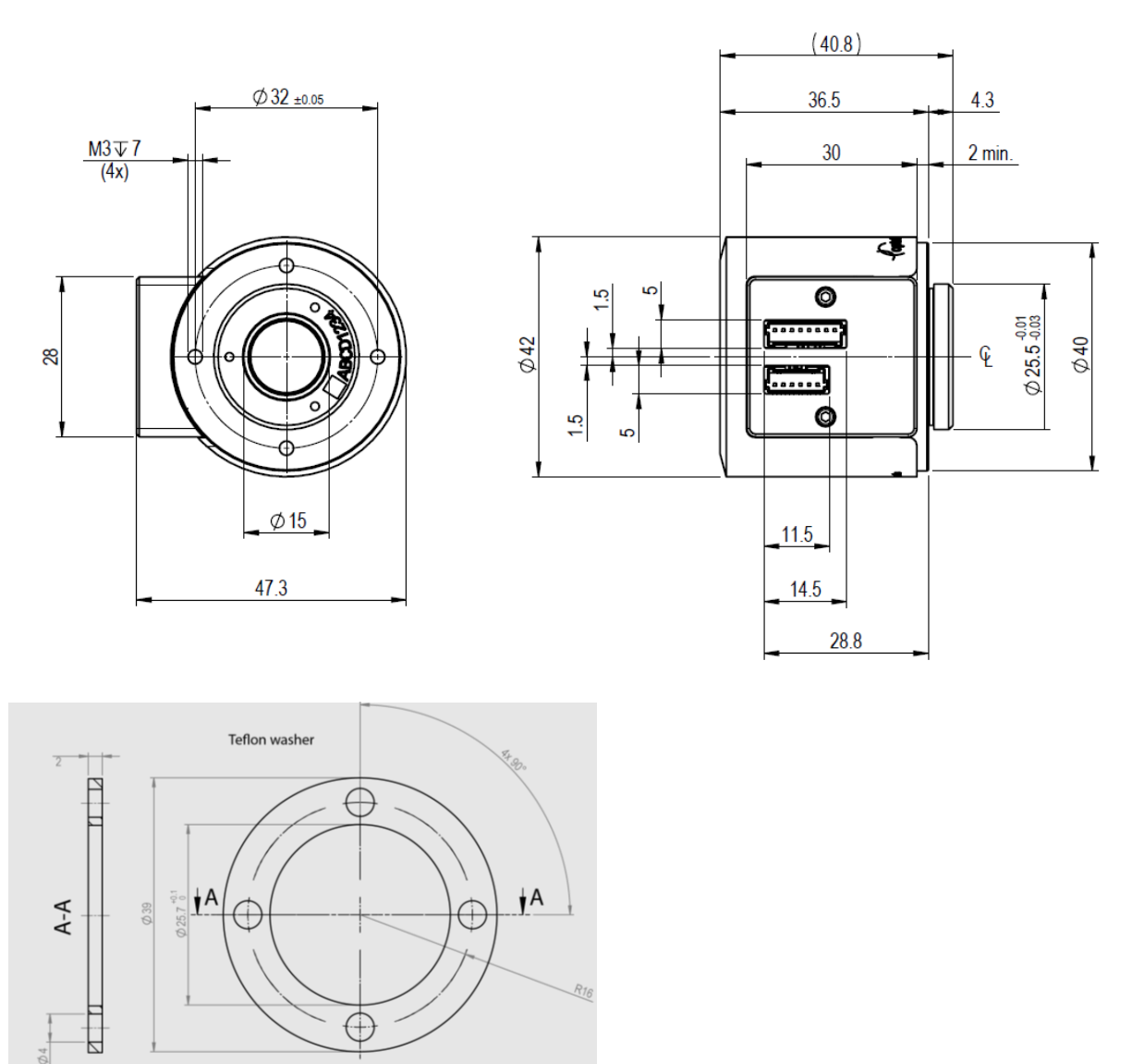

Figure 1: Mechanical layout of the EL-10-42-OF (units: mm). Four M3 thread holes are available for mounting. The Teflon washer has a thickness of 2mm with a flatness tolerance of ± 0.05 mm.

Electrical connection

The electrical connection of the EL-10-42-OF consists of two female 1.5 mm AMP Mini CT connectors with 6 and 8 pins (see e.g. www.te.com, No. 292207-6 and 292207-8). The detailed pin-out is summarized in the table below.

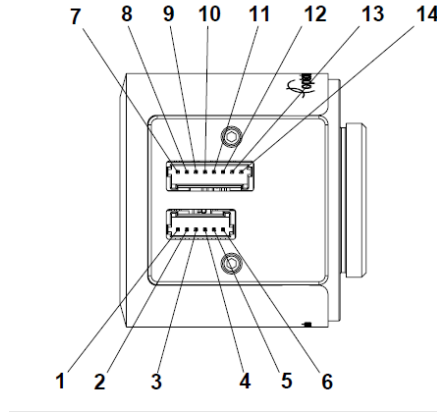

Figure 2: Electrical connections of EL-10-42-OF. Both connectors are of type 1.5 mm AMP Mini CT.

Pinning					
Position	Function	Value	Position	Function	Value
1	GND	-	8	Control current -	-
2	Heater in	Max. 12W	9	GND	-
3	Heater out	-	10	LED + Anode	110mA @ 1.5V
4	I ² C SDA	Digital signal	11	LED – Cathode	-
5	I ² C SCL	Digital signal	12	Photodiode Common Cathode GND	-
6	Vcc	3.3V	13	Photodiode Anode back	Typ. 100 µA
7	Control current +	0..350 mA	14	Photodiode Anode front	Typ. 100 µA

Focal power (focal length) versus current

The focal power of the EL-10-42-OF increases with increased current, shown in Figure 3. The working principle is based on Optotune's well-established technology of electrically tunable lenses. The core that forms the lens contains an optical fluid, which is sealed off with an elastic polymer membrane. An electromagnetic actuator is used to exert pressure on the container and therefore changes the curvature of the membrane such that the focal length is adjusted. By applying the electrical current to the coil of the actuator, the focal power of the lens is controlled.

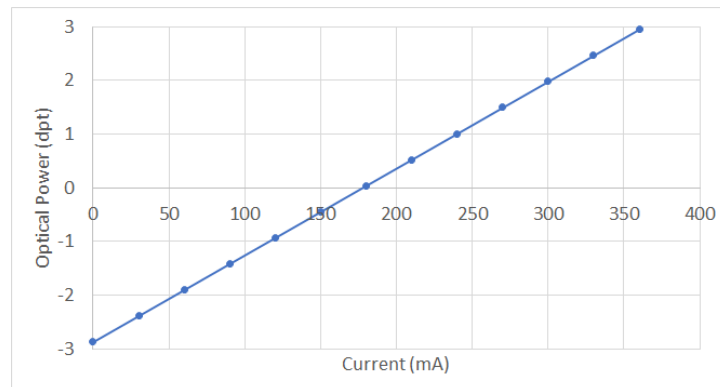

Figure 3: Typical data shows the indicative relation between focal power and electrical current

Optical feedback signal

Optical feedback is used to stabilize the focus of the lens in real time. The way to establish optical feedback is to detect light passing through the lens, emitted from a built-in LED. There are two photodiodes installed inside the lens which are used to measure the LED light. The typical photodiode signals are as shown in Figure 4. The slopes of the two curves are different, and both photo currents strongly depend on the focal power of the lens. With subsequent electronics these currents are converted into voltages through transimpedance amplifiers. The normalized signal $(V1-V2)/(V1+V2)$ of the two voltages V1 and V2 is then calculated in order to perform the optical feedback control for the lens. Note that the normalized signal is independent of intensity fluctuations of the LED.

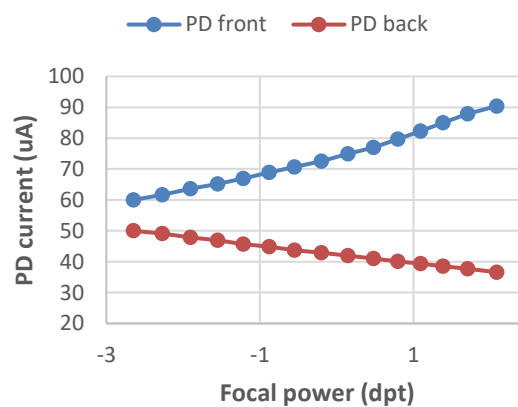

Figure 4: Exemplary output current from two photodiodes versus focal power of the lens.

Alignment and mounting

An important aspect when mounting the EL-10-42-OF is to ensure proper alignment with respect to the optical axis. The figure below shows a possible implementation of a holder plate. For detailed dimensions in your design, we can provide a CAD file of the holder. We recommend referencing the 25.5mm diameter protrusion for axial alignment. The slots on the holder plate allow the rotational freedom required to align the connectors (the relative position of the connectors and the screw holes vary from lens to lens). For best thermal isolation, a Teflon washer (included in the package) shall be placed between the lens and the holder. It is recommended to use plastic screws to fix the lens. The mounting fixture shall include a 10mm aperture stop to reduce the thermal effects on the lens of laser light beyond this diameter.

Note: it is recommended to install with the connectors pointing upwards as detailed below: this is the orientation in which the lens is characterized and tested.



Bode diagram

In order to characterize the dynamics of the EL-10-42-OF itself, which behaves similar to a mass-spring system, it is common to measure the Bode diagram. It contains both the magnitude of the frequency response and the phase shift. The result is shown in Figure 5 which is applicable as a generic model for the EL-10-42-OF. Lens to lens variations are negligible. The first resonance peak is at 200 Hz and in the same region the phase shift reaches -90° and continues to lower values. The diagram gives an indication of the physical limit of the lens' maximum control speed, which will be around 100 Hz (half of the resonance frequency).

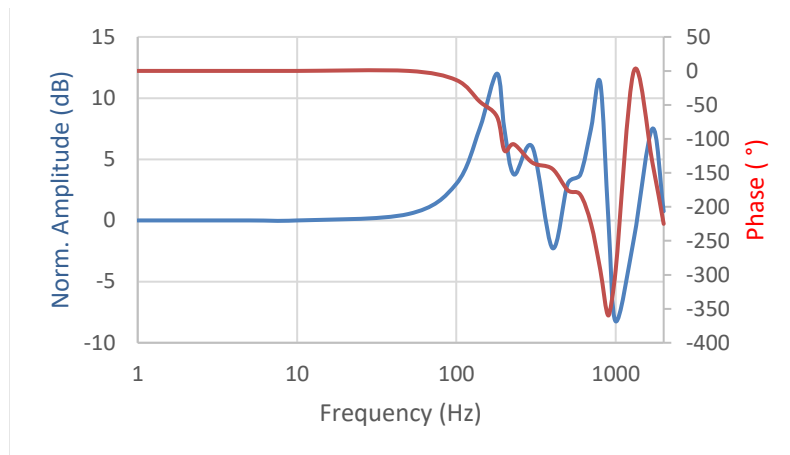

Figure 5: Bode diagram of the EL-10-42-OF. The amplitude is normalized to the DC limit (constant current) and shows a resonance at 200 Hz (blue curve). The phase shift is shown in red.

Temperature stabilization

In order to have the highest focus stability, EL-10-42-OF lens is operated at a temperature of 47°C . This can be achieved using the controller boards we provide. The set temperature is controlled using a PI controller for the heater element. When the lens is initialized, it requires a certain amount of time until the set temperature is reached. In Figure 6, two extreme conditions (environmental temperature of 10°C and 40°C) are demonstrated. The system takes approximately 4 and 6 minutes respectively to get the temperature stable. After a short time, indicated by the red and blue arrows, the lens is set to maximum current (300 mA) in order to see the effect of additional heat input. Even for the 40°C environmental temperature only a small increase of about 2°C is visible, which is the desirable result.

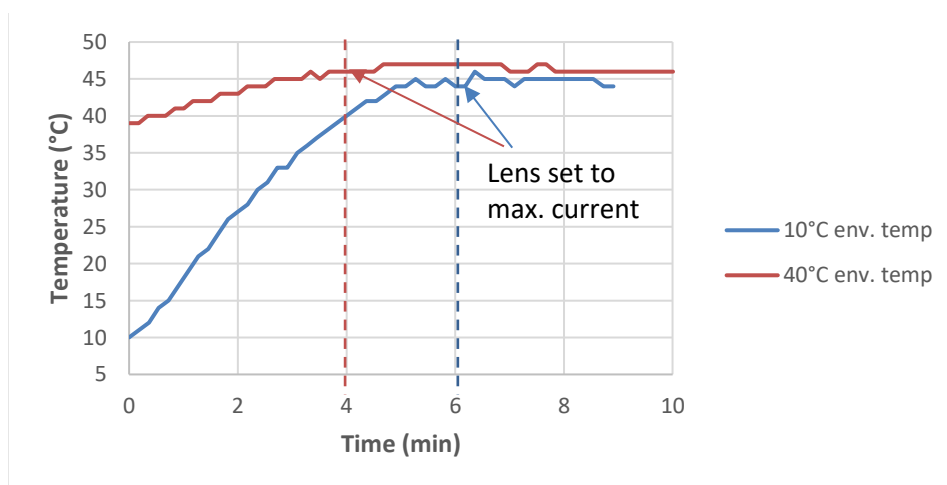

Figure 6: Initial heating phase for two extreme environmental temperatures 10°C and 40°C . It takes approximately 4 and 6 minutes (dashed vertical lines) until the set temperature is reached.

Safety and compliance

The product fulfills the RoHS and REACH compliance standards. The customer is solely responsible to comply with all relevant safety regulations for integration and operation.

For more information on optical, mechanical and electrical parameters, please contact sales@optotune.com